

DESCRIPTION

The ST-16A is a lightweight, smart speaker stand made of aluminum.

SPECIFICATIONS

Effective Extensible Length	1130 - 1660 mm
Load Capacity	7 kg (static load)
Finish	Stand: Aluminum, silver, mat finish Speaker mounting bracket: Polyamide resin, black
Weight	1.7 kg (bracket included)
Accessory	Speaker mounting screw (M5 × 20) ×2, Hexagon headed bolt (M8 × 20) ×1, Washer ×1, Spacer ×1, Butterfly nut ×1

APPEARANCE

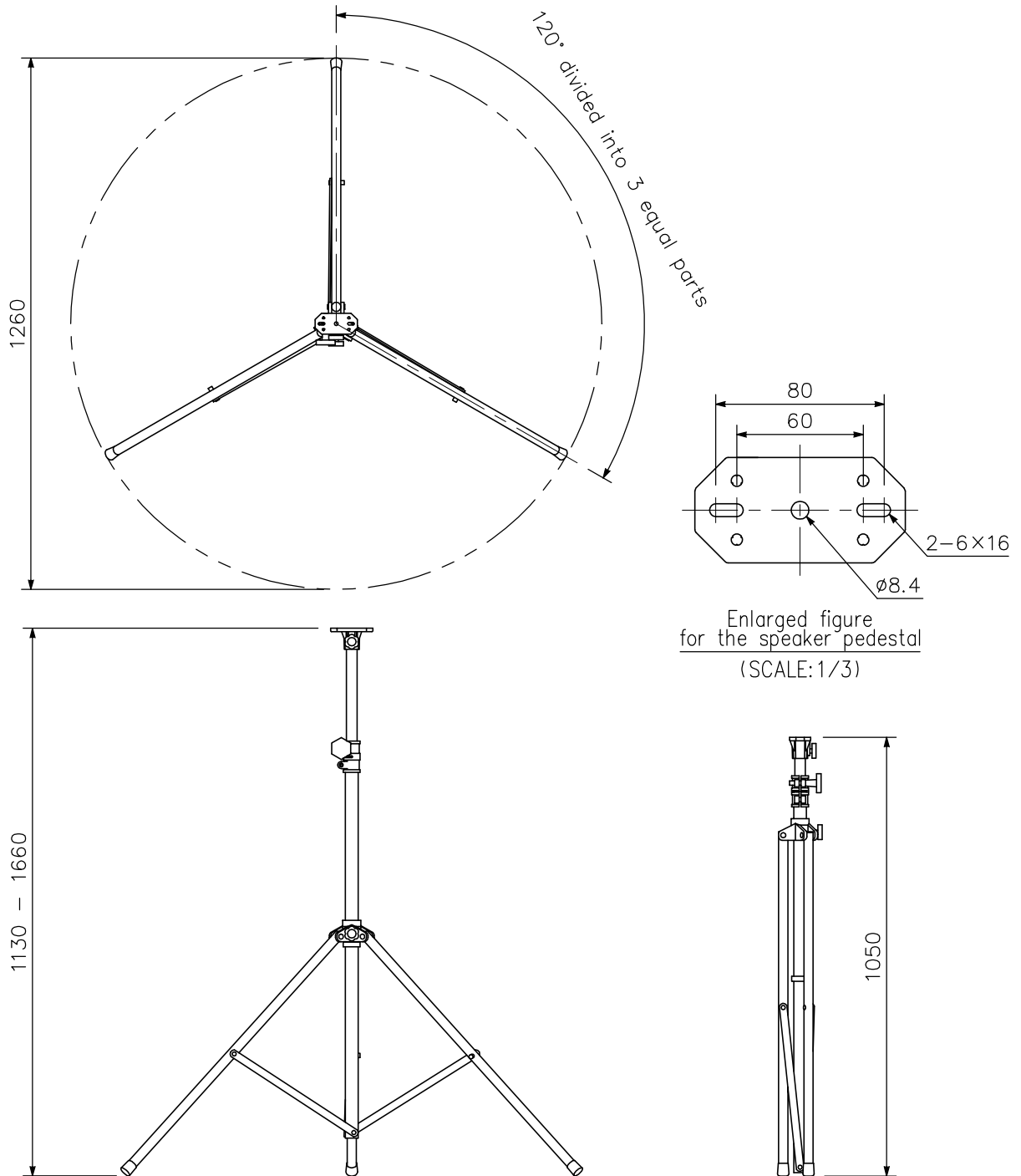

UNIT:mm SCALE:1/15

When folded