

DESCRIPTION

The ZS-1034S can be installed easily on the wall with help of the plug-in speaker receptacle.

SPECIFICATIONS

Rated Input	10 W
Rated Impedance	100 V line: 1 kΩ (10 W), 2 kΩ (5 W), 3.3 kΩ (3 W), 10 kΩ (1 W) 70 V line: 500 Ω (10 W), 1 kΩ (5 W), 2 kΩ (2.5 W), 3.3 kΩ (1.5 W), 10 kΩ (0.5 W)
Sensitivity	90 dB (1 W, 1 m)
Frequency Response	120 Hz – 20 kHz
Speaker Component	Low frequency: 12 cm (5") cone-type, High frequency: Balanced dome-type
Input Connector	M4 screw terminal, distance between barriers: 11 mm (0.43")
Finish	Enclosure: HIPS resin (fire resistant grade UL94 V-0 or its equivalent), silver Net: Steel plate, silver, paint
Dimensions	208 (W) x 327 (H) x 79 (D) mm (8.19" x 12.87" x 3.11")
Weight	1.4 kg (3.09 lb)
Accessory	Speaker receptacle ...1, Wall mounting screw ...2

APPEARANCE

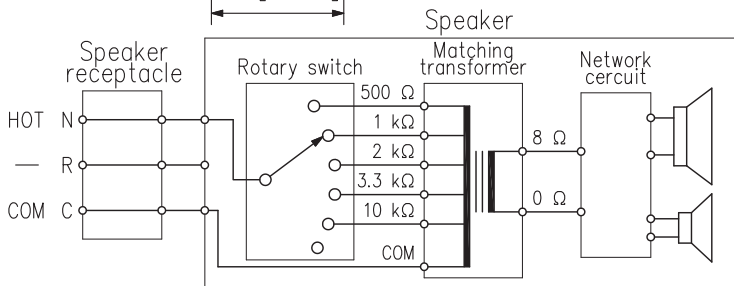
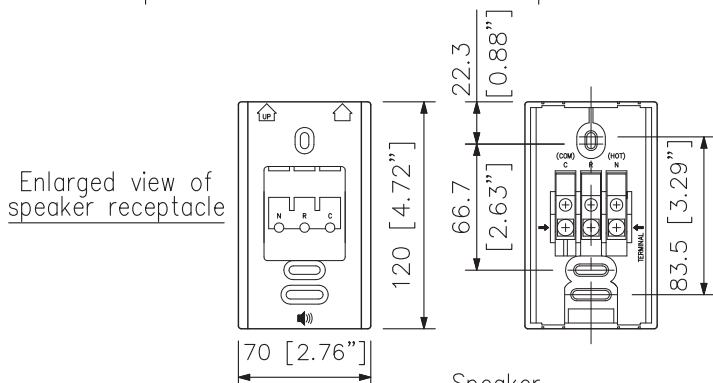
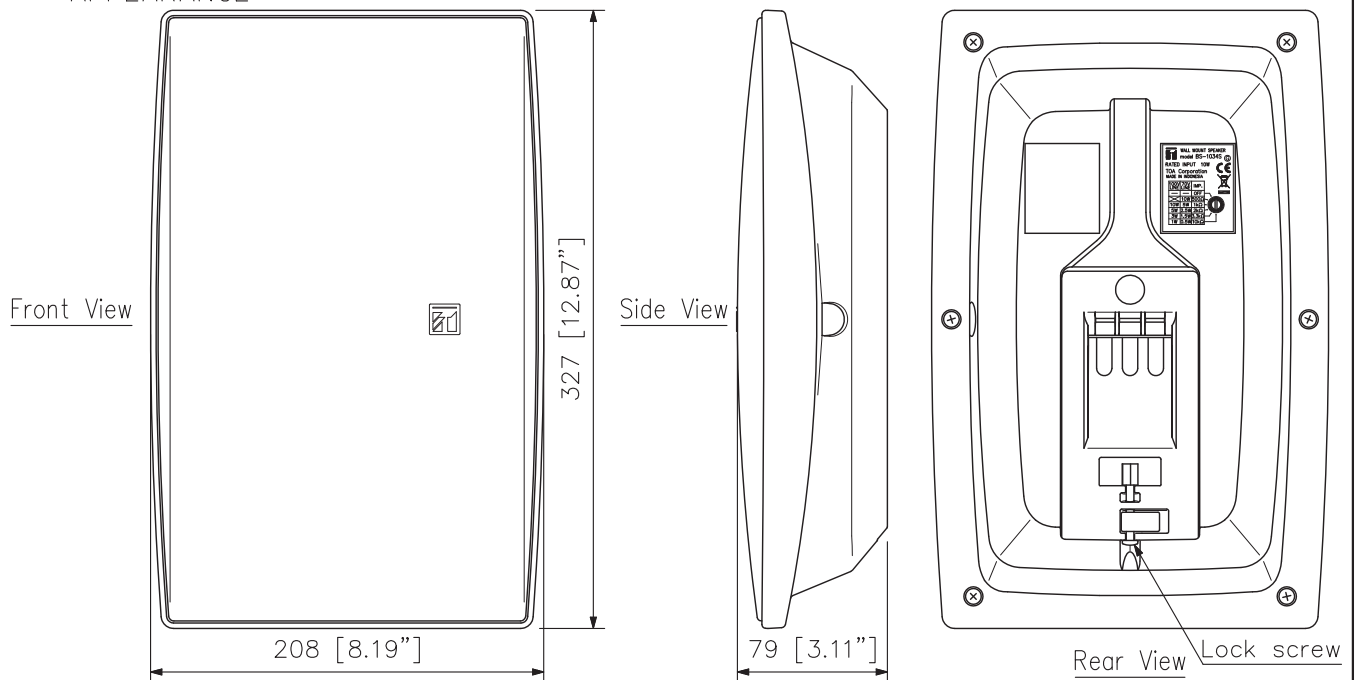

(Factory-preset wiring)
Note: Never connect to the 500 Ω in a 100 V line system.
Wiring Diagram

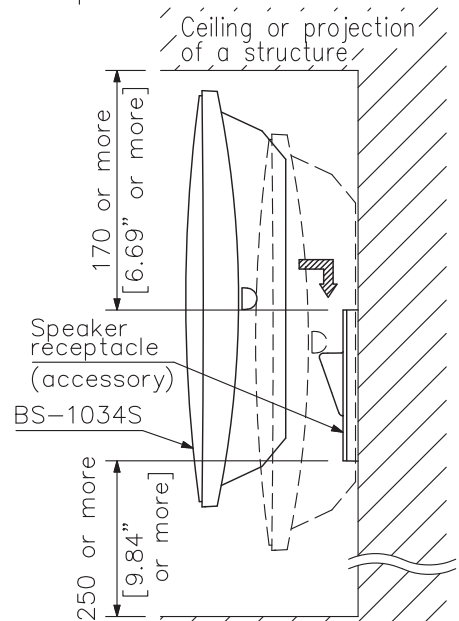

Note: As a force of approx. 18 kg (39.68 lb) is applied to the speaker receptacle at the time of speaker installation, attach it in a location durable enough to withstand the force.
Installation view (scale: 1/6)

UNIT:mm SCALE:1/4