

DESCRIPTION

The ZT-200 is a matching transformer for the Z-5HX2 series and Z-HX7 series speaker systems, and can be used both indoors and outdoors.

SPECIFICATIONS

Rated Input	200 W
Primary Impedance	100 V line: 50 Ω (200 W), 83 Ω (120 W), 167 Ω (60 W) 70 V line: 25 Ω (200 W), 50 Ω (100 W), 83 Ω (60 W), 167 Ω (30 W)
Secondary Impedance	8 Ω
Water Protection	IPX4 (the tilt angle must be within 45°) *
Finish	Cover: Polypropylene Mounting bracket: Stainless steel (SUS304)
Dimensions	164 (W) × 141 (H) × 129 (D) mm
Weight	2.8 kg
Accessory	Speaker mounting bolt (M8) with washer ×2

APPEARANCE

※ When the matching transformer is installed on Z-5HX2 series rear mounting plate, the optional ZY-WM1 series and ZY-CW1 series Speaker Mounting Brackets, and ZY-ST1 Speaker Stand Adapter cannot be used.

※ When mounting the matching transformer to the Z-HX7 series, an optional ZY-MT7 Matching Transformer Adapter is required.

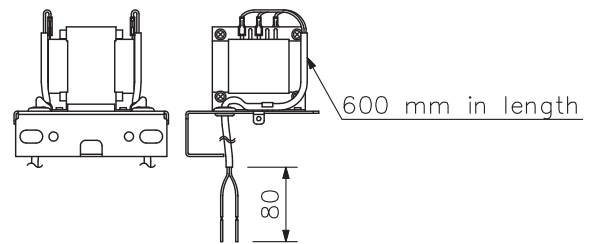
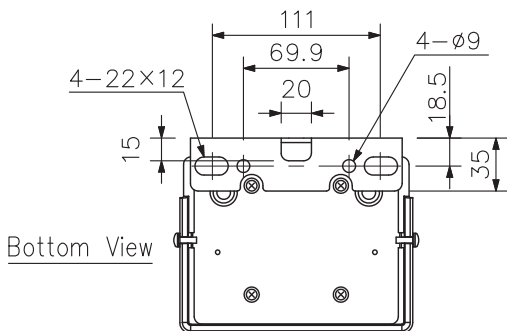
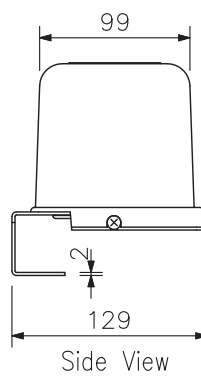
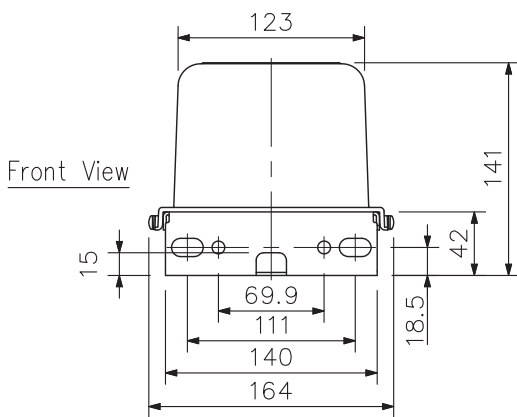
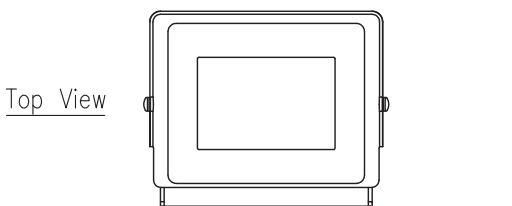

Matching transformer without cover (scale: 1/7)

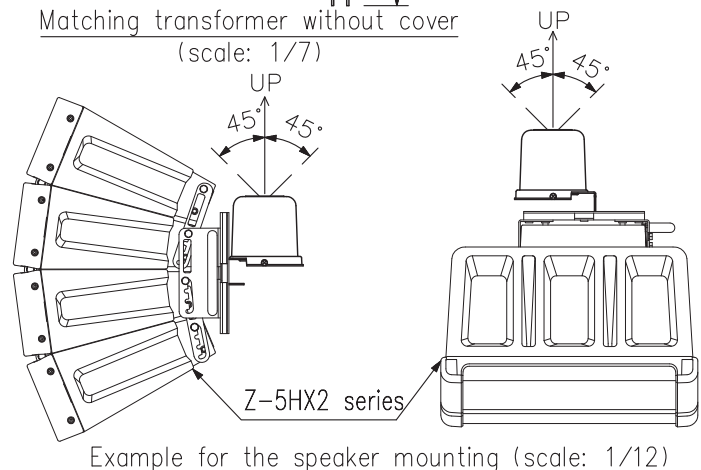
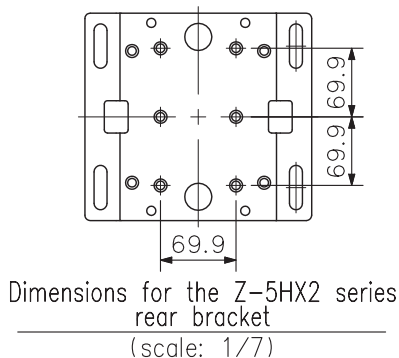

* When installed outdoors, mount the ZT-200 in either way that the tilt angle of its top surface is kept within 45° from the vertical axis. Exceeding this angle will deteriorate the speaker's water-resistant capability.

UNIT:mm SCALE:1/5