

### DESCRIPTION

The Z-2352SC ceiling-mounted speaker covers an extremely wide area and can be used for 70V & 100V line applications. Well-balanced sound can be heard uniformly at any location.

### SPECIFICATIONS

Rated Input	6 W (High Impedance)
Power Handling Capacity	Continuous pink noise: 9 W (8 Ω) Continuous program: 18 W (8 Ω)
Impedance	100 V line: 1.7 kΩ (6 W), 3.3 kΩ (3 W), 10 kΩ (1 W), 20 kΩ (0.5 W) 70 V line: 830 Ω (6 W), 1.7 kΩ (3 W), 3.3 kΩ (1.5 W), 10 kΩ (0.5 W), 20 kΩ (0.25 W) 8 Ω
Sensitivity	89 dB (1 W, 1 m)
Frequency Response	80 Hz - 20 kHz (-10 dB), 50 Hz - 20 kHz (-20 dB) at installation in 1/2 free sound field (Measured by installing the unit in the center of a ceiling.)
Speaker Component	High frequency: Balanced dome-type Low frequency: 12 cm cone-type
Mounting Hole	∅200 mm (Maximum ceiling thickness: 37 mm)
Input Terminal	Push-in connector (Bridging terminal-2 branch type)
Usable Cable	600 V Vinyl-insulated cable (IV wire or HIV wire) Solid copper wire: ∅0.8 - ∅1.6 mm (equivalent to AWG No. 20 - 15) 7-core twisted copper wire: 0.75 - 1.25 mm <sup>2</sup> (equivalent to AWG No. 18- 17)
Finish	Baffle: Fire-resistant ABS resin (resin material grade: UL-94 V-0), black Rim: Fire-resistant ABS resin (resin material grade: UL-94 V-0), white, paint Punched net: Steel plate, white, paint Dust-proof bag: Artificial fiber, black
Dimensions	∅230 × 154 (D) mm
Weight	1.5 kg (including panel)
Accessory	Panel ...1, Paper pattern ...1

### APPEARANCE

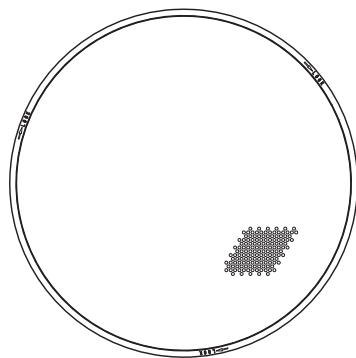

Front View

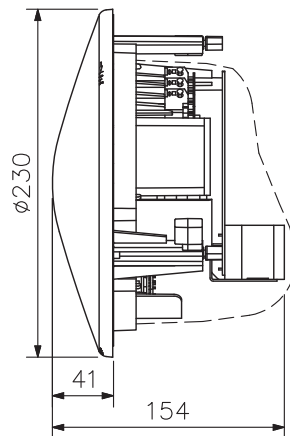

Side View

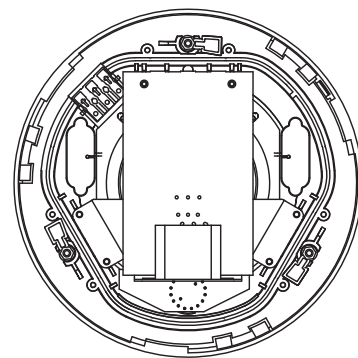

Rear View

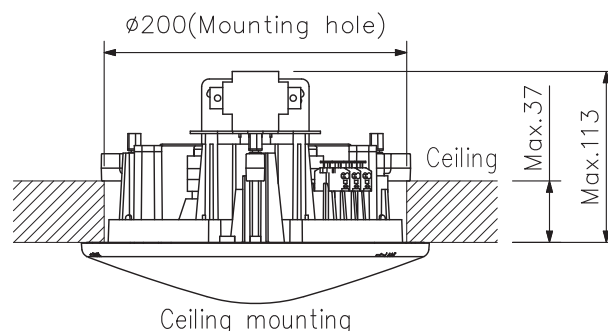

Ceiling mounting

UNIT: mm SCALE: 1/5