

■DESCRIPTION

The **ZR-1015** is an easy-to-operate, hand grip type megaphone rated at 15 W of output. The newly developed polyimide diaphragm is employed to ensure high sound quality.

■SPECIFICATIONS

Power Source	R14P (C) × 6 (9 V DC)
Rated Output	15 W
Maximum Output	23 W
Battery Life	Approx. 14 hours (JEITA)*
Audible Range	Approx. 315 m (JEITA)*
Diaphragm	Polyimide film (voice coil, bobbin)
Operating Temperature	-10 °C to +40 °C
Finish	Horn: ABS resin, off-white Mouth, battery case and handle: ABS resin, light blue Strap: Nylon, black
Dimensions	210 (W) × 291 (H) × 319 (D) mm
Weight	970 g (without batteries)

Note: Batteries are optional.

* JEITA: Japan electronics and information technology industries association. (EIAJ TT-4501A)

■APPEARANCE

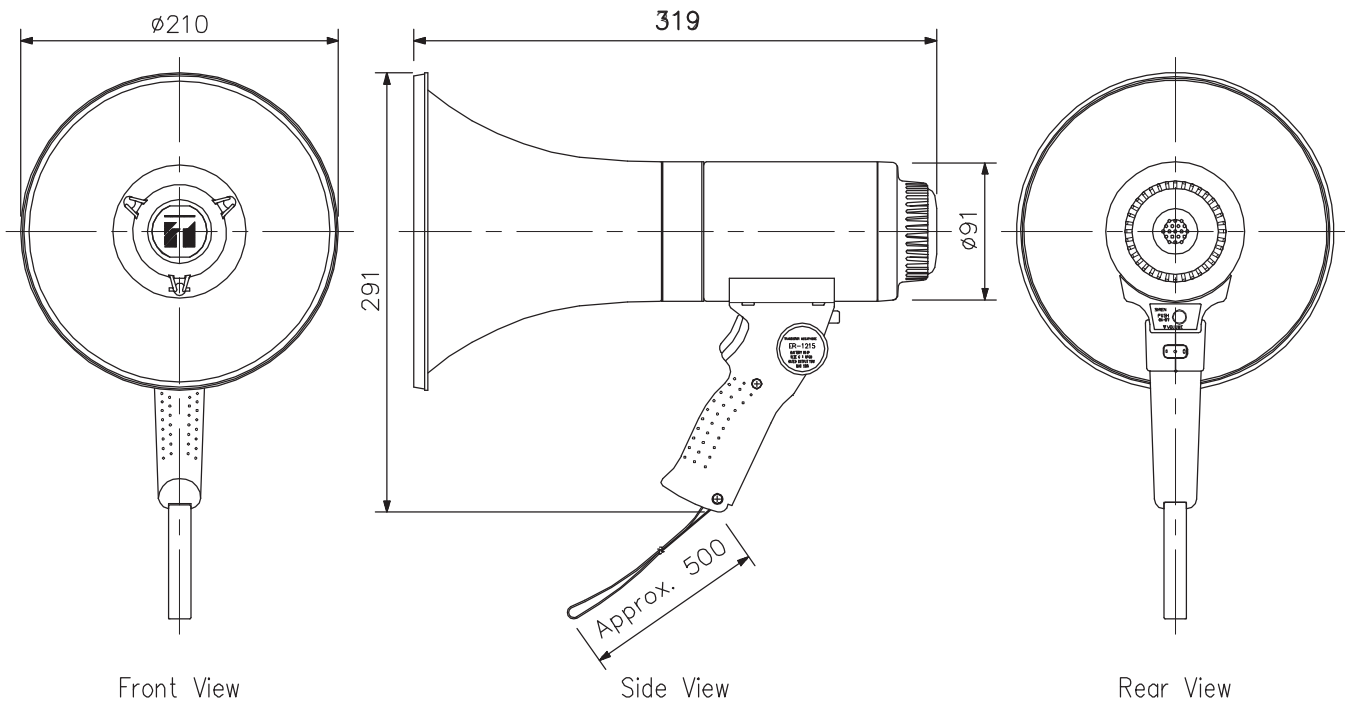

<Note on the audible range and battery life>

1. The indications of the audible range and battery life are based on the JEITA Standard*.
2. Audible range presumes that the megaphone employs new batteries and is used on a quiet street.
It varies depending on such conditions as battery consumption, ambient noise, wind direction, and obstacles.
3. Battery life assumes that megaphone is used for 30 minutes a day.

UNIT:mm SCALE:1/5