

■ **DESCRIPTION**

The ZS-F1000B is speakers are compact two-way speaker systems designed for high efficiency, wide range, and high power input handling capability. These speaker systems can be installed and used many different applications with combined use of the supplied accesories or the optional mounting brackets.

■ **SPECIFICATIONS**

Rated Impedance	8Ω
Sound Pressure Level	87 dB (1W,1m) at installation in a semianechoic field
Frequency Response	85 - 20,000 Hz, -10 dB at installation in a semianechoic field
Directivity Angle	Horizontal: 90°, Vertical: 90°
Speakers	Woofers: 10 cm cone-type Tweeter: balanced dome-type
Input Terminals	Push-in terminals
Finish	Enclosure: HIPS, black Mesh Speaker Grill: Surface-treated steel plate, black, paint Speaker Bracket: Aluminium die-cast, black, paint Joint Bracket, Wall Bracket: Steel plate, t1.6, black, paint
Dimensions	130(w) x 202(h) x 131(d) mm
Weight	1.8 kg (including the supplied brackets)
Acessories	Speaker bracket ..1, Joint bracket ..1, Wall bracket ..1, Fixing bolt M5x60 ..1, Hexagon bolt M6x12 (with plain washer and spring washer) ..2, Machine screw M5x20 (with plain washer and spring washer) ..2
Optional Products	Board hanger bracket: ZY-BH10B Ceiling mount bracket: ZY-CM10B Cluster Bracket: ZY-CL10B Speaker stand: ST-16A

■ **APPEARANCE**

[Top]

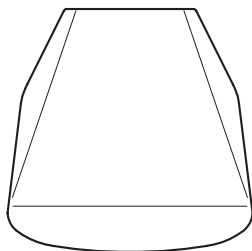

[Bottom]

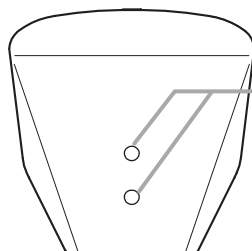

Mounting holes

Note:

Hole seals are adhered over the holes at the factory. Before attaching the speaker mounting bracket to this side, remove them using a pointed tool.

[Front]

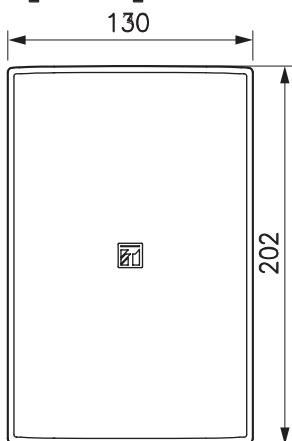

[Side]

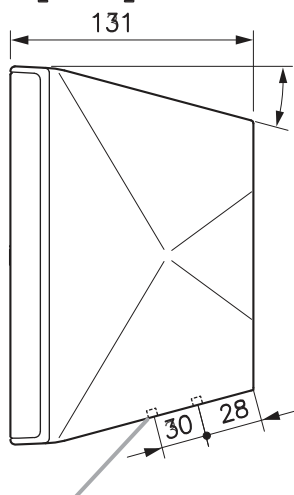

[Rear]

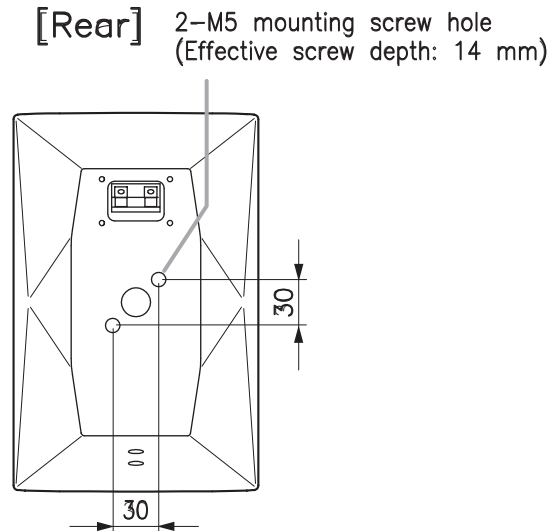

2-M5 mounting screw hole
(Effective screw depth: 14 mm)

Unit : mm Scale : X/X