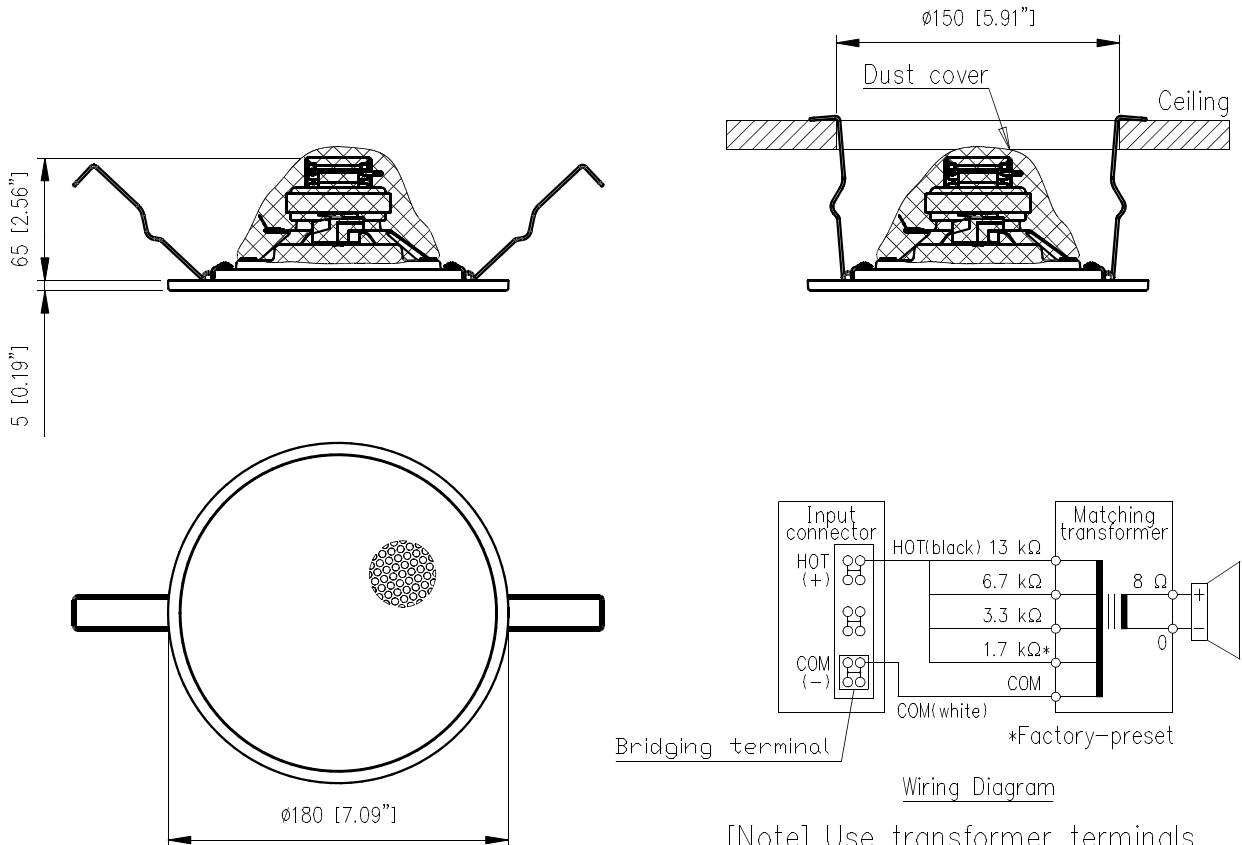

DESCRIPTION

The ZS-1860-AS Ceiling Mount Speaker is of all metallic construction and ideal for use in a voice alarm system or BGM system. It features a spring clamp mechanism for easy mounting to the ceiling. The input impedance can be easily changed by changing the tap position of the transformer. The push-in type input terminal block makes cable connection easy and allows bridge wiring.

SPECIFICATIONS

Rated Noise Power	6 W (100 V Line), 3 W (70 V Line)
Rated Impedance	100 V line: 1.7 kΩ (6 W), 3.3 kΩ (3 W), 6.7 kΩ (1.5 W), 13 kΩ (0.8 W) 70 V line: 1.7 kΩ (3 W), 3.3 kΩ (1.5 W), 6.7 kΩ (0.8 W), 13 kΩ (0.4 W)
Sensitivity	94 dB (1 W, 1 m) (330 Hz – 3.3 kHz, pink noise)
Frequency Response	55 Hz – 20 kHz (pink noise –20 dB)
Speaker Component	12 cm (5") cone-type
Dimension for Fixing Hole	Mounting hole: $\phi 150 \pm 3$ mm [5.91" \pm 0.12"] Ceiling Thickness: 5 – 25 mm [0.2" – 0.98"]
Speaker Mounting Method	Suspension spring
Applicable Cable	Solid wire: 0.5 – 3 mm ² (AWG20–12)
Connection	Push wire connection (Bridging terminal 2-branch type)
Finish	Frame: Steel plate, white (RAL 9016 equivalent), paint Grille: Steel net, white (RAL 9016 equivalent), paint
Dimensions	$\phi 180 \times 5$ (exposed section) + 65 (D) mm ($\phi 7.09" \times 0.19" + 2.56"$)
Weight	590 g (1.30 lb)

APPEARANCE

[Note] Use transformer terminals when changing input impedance.

UNIT : mm [in] SCALE : 1/4