

DESCRIPTION

The ZS-HS1200BT is a 2-way speaker system made of resin, and features a large diameter woofer. It can be installed and used in many different applications with combined use of the supplied accessories and/or the optional mounting brackets.

SPECIFICATIONS

Enclosure	Sealed type
Rated Input	60 W (High Impedance)
Power Handling Capacity	Continuous pink noise: 100 W (Low Impedance) Continuous program: 300 W (Low Impedance)
Rated Impedance	8 Ω 100 V line: 170 Ω (60 W), 330 Ω (30 W), 670 Ω (15 W) 70 V line: 83 Ω (60 W), 170 Ω (30 W), 330 Ω (15 W), 670 Ω (7.5 W)
Sensitivity	97 dB (1 W, 1 m)
Frequency Response	70 Hz - 20 kHz
Crossover Frequency	3 kHz
Directivity Angle	Horizontal: 90°, Vertical: 40°
Speaker Component	Low frequency: 30 cm (12") cone-type, High frequency: Balanced dome tweeter × 6
Input Terminal	NEUTRIK NL4MP Speakon and M4 screw terminal, distance between barriers: 9 mm (0.35")
Operating Temperature	-10 °C to +50 °C (14 °F to 122 °F)
Finish	Enclosure: Polypropylene, black Punched net: Surface-treated steel plate, black
Dimensions	361 (W) × 448 (H) × 320 (D) mm (14.21" × 17.64" × 12.6")
Weight	10 kg (22.05 lb)
Accessory	Handle ×1, Handle fitting bracket ×2, Handle mounting screw ×2, Rubber foot ×2, Rubber foot mounting screw ×2
Option	Mounting bracket: ZY-1200VB (for vertical speaker mounting) ZY-1200HB (for horizontal speaker mounting)

APPEARANCE

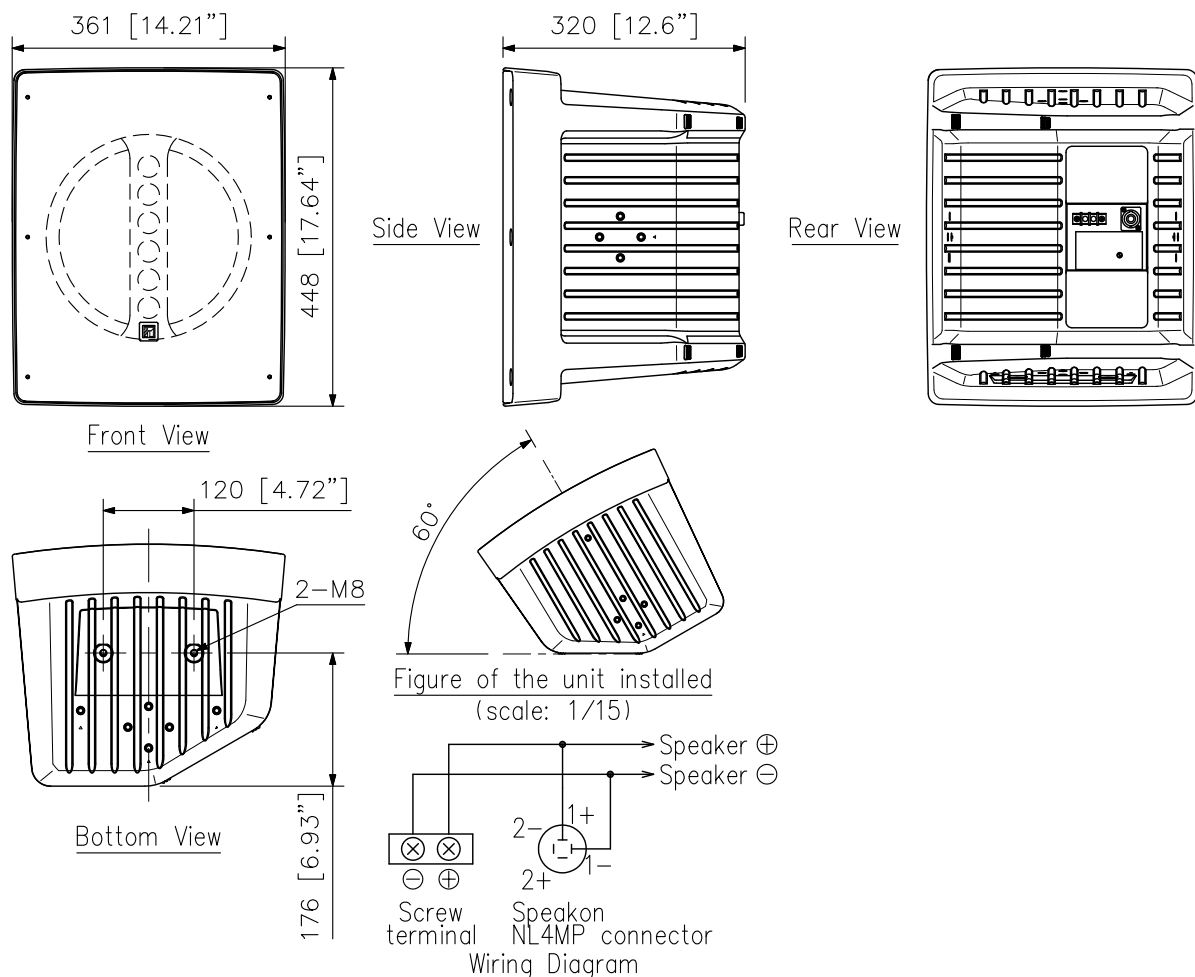

UNIT:mm SCALE:1/10