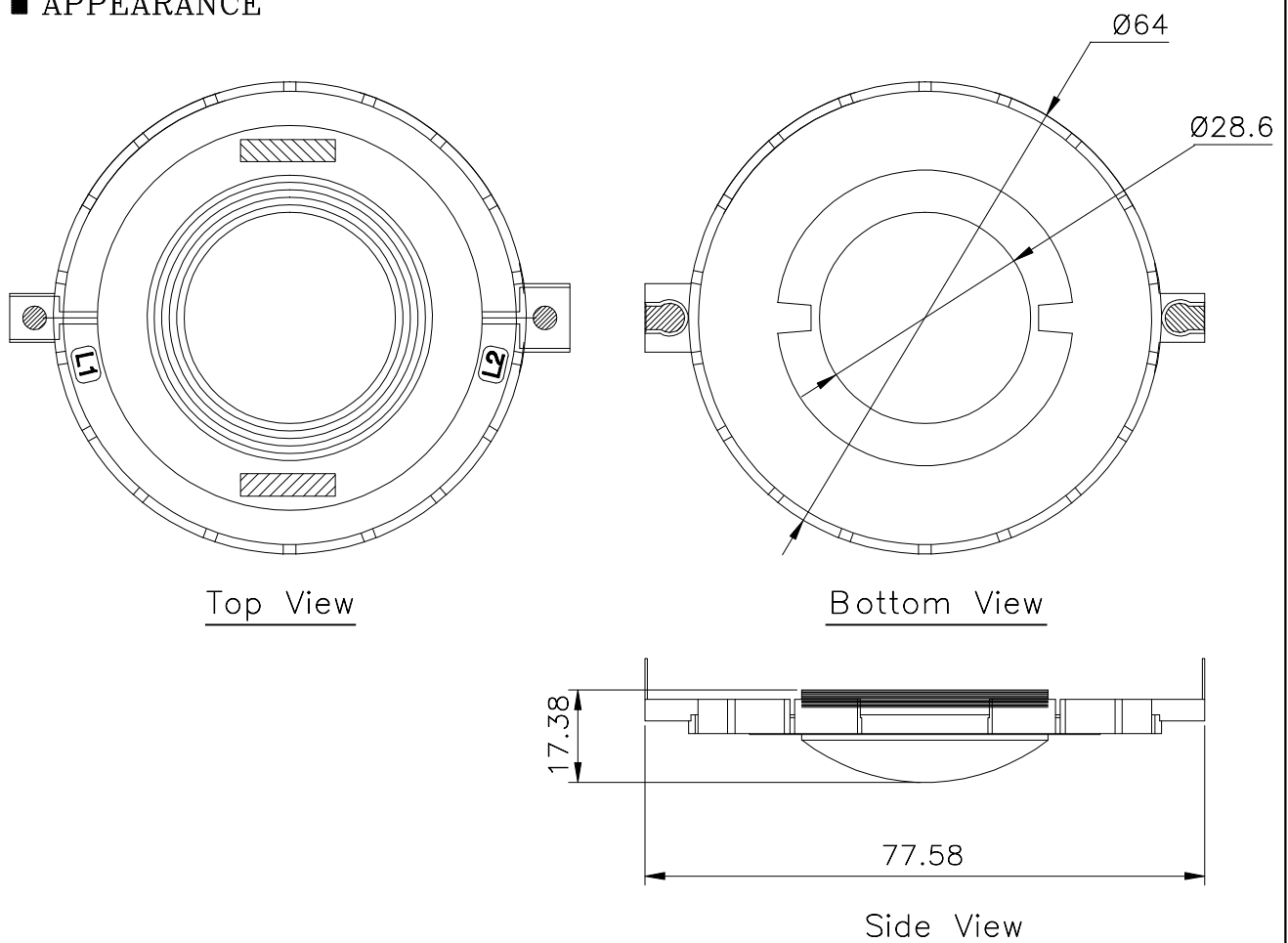

DESCRIPTION

TOA's ZG-60B-A is speaker diaphragm that mainly part of horn speaker/megaphones. A designated by polymade material, that can produce good quality sound and strong to power handling.

SPECIFICATION

| | |
|----------------------|---|
| Applicable model | ZH-610S/SM, ZH-615S/SM, ZH-615R/RM, ZR-1015/S, ZR-2015/S/SP/W, ZR-510/S, ZR-604W, ZR-1215, ZR-3215/S, ZR-2215/W |
| Rated Input | 15W (When operated with ZH-615S) |
| Rated Impedance | 8Ω |
| Sound Pressure Level | 109dB (1W, 1m) |
| Frequency Response | 333 ~ 10,511 Hz (When operated with ZH-615S) |
| Dimensions | Ø64mm x Ø28.6(D)mm |
| Weight | 8.81 g (0.019 lb) |

APPEARANCE

UNIT:mm SCALE:1/1