

■ DESCRIPTION

The ZM-270 is a moving coil type microphone featuring high intelligibility suitable for vocal application

■ SPECIFICATIONS

Type	Moving coil microphone
Directivity	Unidirectional
Rated Impedance	600 ohms, balanced
Rated Sensitivity	-52 dB (1kHz, 0dB = 1 V/Pa)
Frequency Response	100 Hz ~ 15 kHz
Connection Cable	Separate type, 1-core shielded cable, unbalanced
Cable Length	5 m
Terminal Cable	Phone plug
Connector	XLR-3 type
Talk Switch	Short-off, slide switch
Finish	Body : Zinc die cast, painted black Head : Steel wire, painted black
Dimensions	∅47 X 175 mm (microphone body)
Weight	300 g (without connection cable)
Accessories	Microphone holder (W 5/16" 18 thread)

■ APPEARANCE

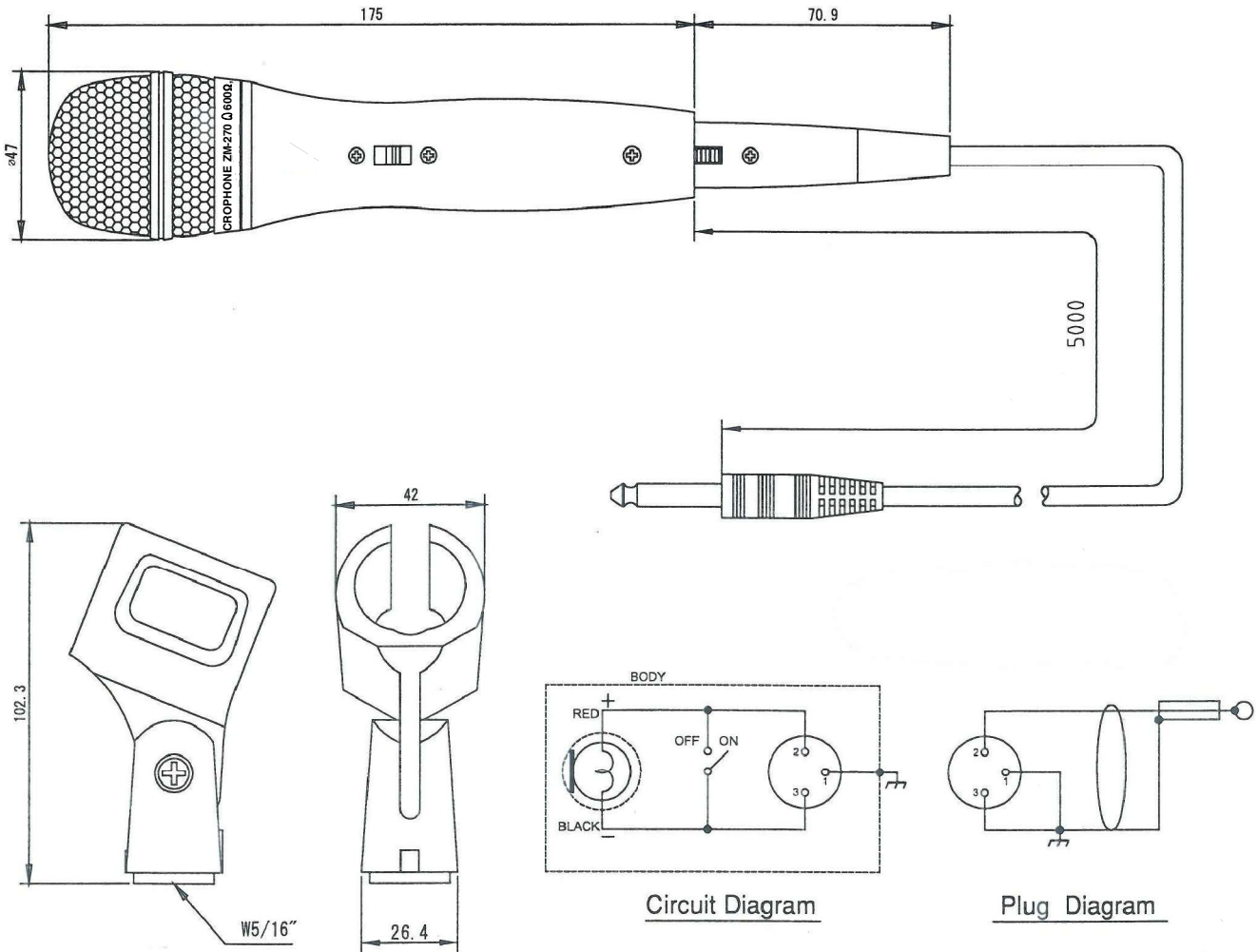

UNIT: mm SCALE: 1/2