

HORN SPEAKER

DESCRIPTION

The ZH-5025BM is designed to be used exclusively in the paging or intercom system. Its impedance can be easily changed with a standard screwdriver. To avoid the unit's, do not sound a signal tone from this speaker for long periods of time.

SPECIFICATIONS

| | | | |
|--------------------------------|--|----------------|--|
| Model | ZH-5025BM | | |
| Input | Rated 25W | | |
| Line Voltage | 100V | | |
| Impedance | 400Ω (25W), 670Ω(15W), 1kΩ(10W), 2kΩ(5W) | | |
| Sound Pressure Level (Average) | 110dB (1W, 1M) at (Hz) 500, 1000, 1500, 2000 | | |
| Frequency response (Hz) | 200 ~ 6,000 | | |
| Ambient Temperature | -20°C to +55°C | | |
| Finish | 1 | HORN-A | Aluminium, off white |
| | 2 | REFLECTOR HORN | ABS resin, off white |
| | 3 | BRACKET | Steel, off white |
| | 4 | BRACKET HOLDER | ADC, off white |
| | 5 | REAR COVER | ABS resin, grey |
| | | SCREW & BOLT | Steel, electro plating (chromate) |
| | | SPEAKER CABLE | Polyvinyl chloride insulated cabtyre cable |
| Weight | 4.7kg | | |

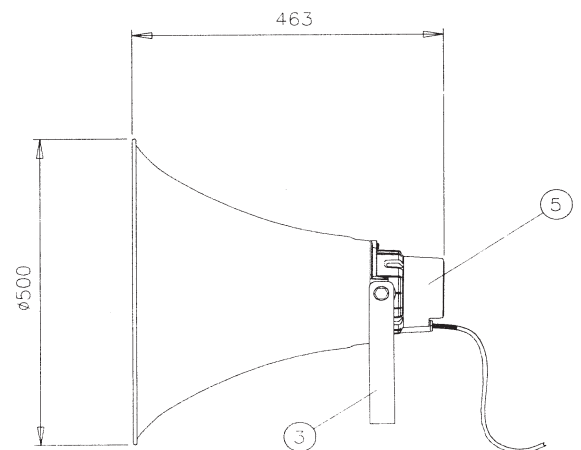
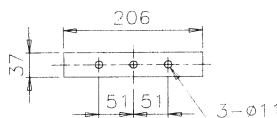
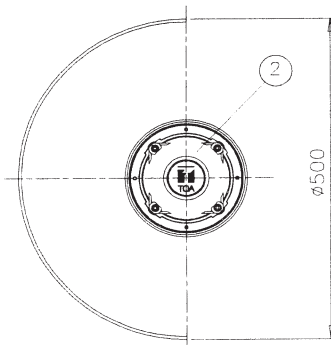
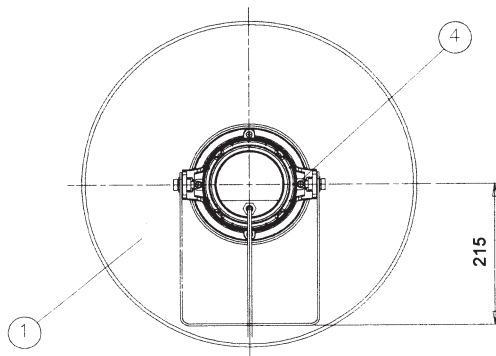
APPEARANCE

Connection diagram

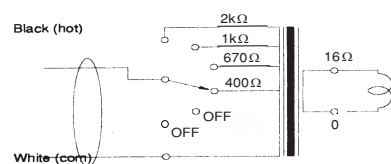

UNIT : MM