

# PAGING HORN SPEAKER

## ● DESCRIPTION

The ZH-615SM is designed to be used exclusively in the paging or intercom system. Its impedance can be easily changed with a standard screwdriver. To avoid the unit's, do not sound a signal tone from this speaker for long periods of time.

## ● SPECIFICATIONS

Model	ZH-615SM	
Input	Rated 15W	
Line Voltage	100V	
Impedance	670Ω (15W), 1kΩ(10W), 2kΩ(5W), 3.3kΩ(3W)	
Sound Pressure Level	≥ 109dB (1W, 1M) (at 500 ~ 2.5kHz peak level)	
Frequency response	Low : ≤ 333      High : ≥ 10,511	
Sensitivity as microphone ( 0dBm = 1mW / 10dyne / cm <sup>2</sup> )	-20dBm at 1kHz	
Ambient Temperature	-20°C to +55°C	
Finish		
1 HORN-A	Aluminium (off white)	
2,5 HORN-BC, REAR COVER	Weather proof as ABS resin (off white)	
3 BRACKET HOLDER	Aluminium die cast (off white)	
4 BRACKET	Steel (dark grey)	
Weight	1.3kg	

## ● APPEARANCE

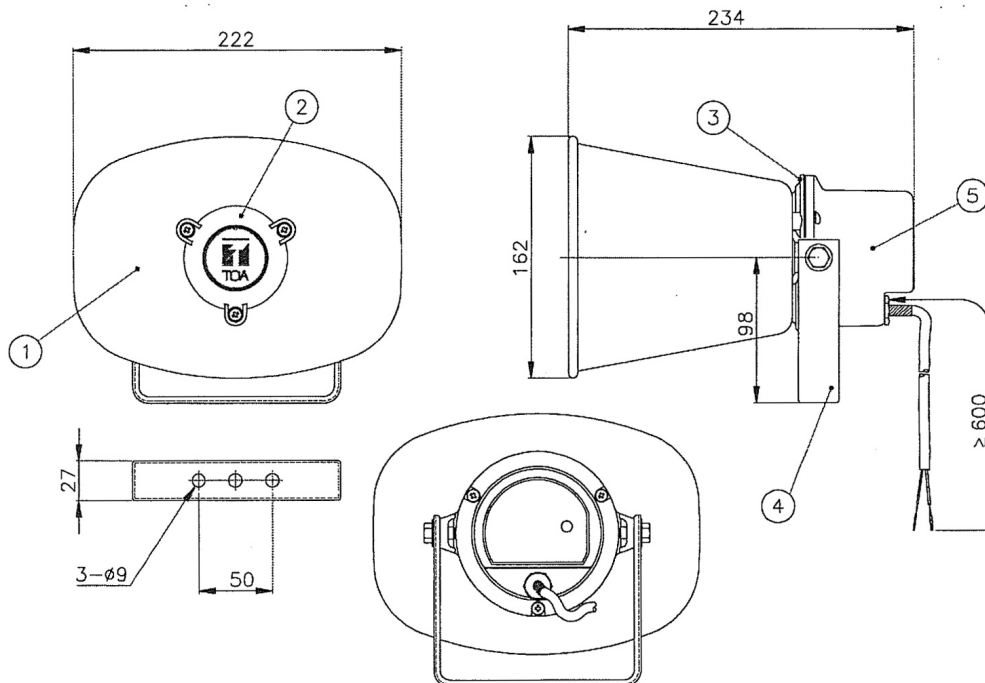

### Connection diagram

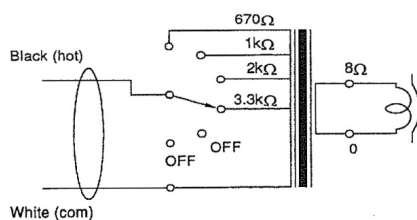

UNIT : MM