

# PAGING HORN SPEAKER

**DESCRIPTION**

The ZH-610SM is designed to be used exclusively in the paging or intercom system. Its impedance can be easily changed with a standard screwdriver. To avoid the unit's, do not sound a signal tone from this speaker for long periods of time.

**SPECIFICATIONS**

Model	ZH-610SM	
Input	Rated 10W	
Line Voltage	100V	
Impedance	1kΩ (10W), 2kΩ(5W), 3.3kΩ(3W), 10kΩ(1W)	
Sound Pressure Level	≥ 107dB (1W, 1M) (at 500 ~ 2.5kHz peak level)	
Frequency response	Low : ≤ 375      High : ≥ 10,511	
Sensitivity as microphone ( 0dBm = 1mW / 10dyne / cm <sup>2</sup> )	-24dBm at 1kHz	
Ambient Temperature	-20°C to +55°C	
Finish		
1 HORN-A	Aluminium (off white)	
2,5 HORN-BC, REAR COVER	Weather proof as ABS resin (off white)	
3 BRACKET HOLDER	Aluminium die cast (off white)	
4 BRACKET	Steel (dark grey)	
Weight	1.2kg	

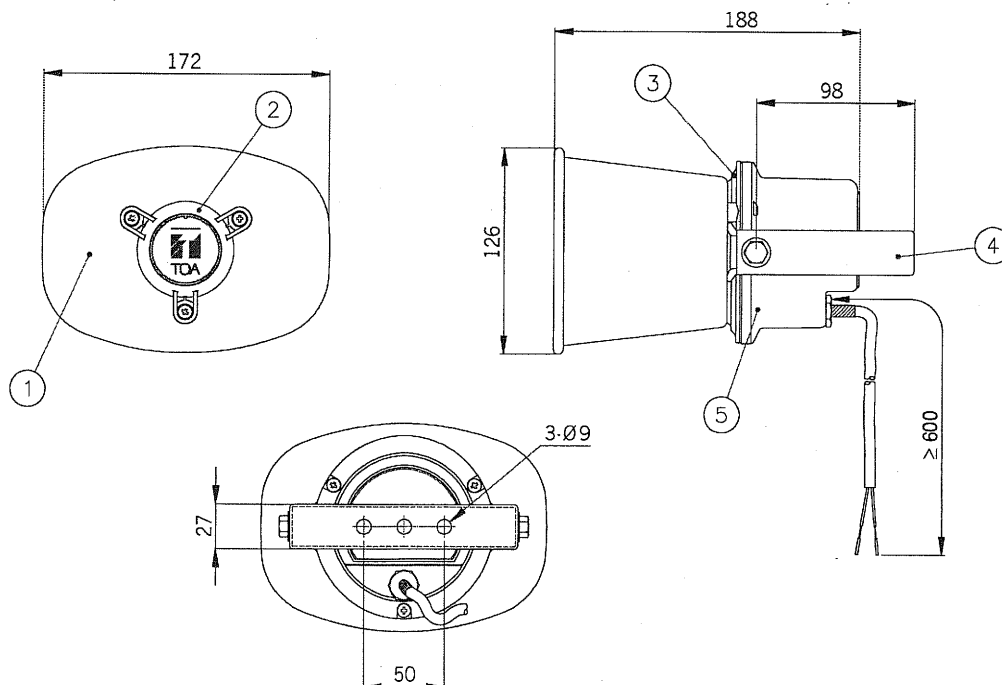
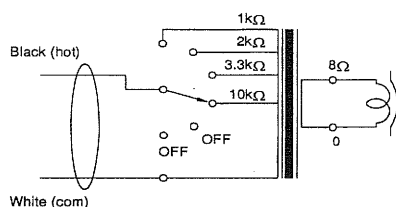
**APPEARANCE**

**Connection diagram**

UNIT : MM