

DESCRIPTION

The ZH-652MD is a highly intelligible driver unit suited to public address announcement applications. Use the driver unit in combination with a suitable horn (optional). Its powder-coated finish and stainless steel screws ensure the unit's weatherproof capability.

SPECIFICATIONS

Applicable Horn	ZH-652T
Rated Input	50 W
Line Voltage	100 V line
Rated Impedance	100 V line: 200 Ω (50 W), 330 Ω (30 W), 670 Ω (15 W)
Output Sound Pressure Level	110 dB (1 W, 1m) (When operated with JIS C 5504 standard horn.)
Frequency Response	150 - 6,000 Hz (When operated with JIS C 5504 standard horn.)
IP Code	IP 65 (When a driver is operated with a horn.)
Horn Coupling	1 - 3/8 18 threads (inch screw)
Polarity	Hot: Black, Com: White
Operating Temperature	-20° C to +55° C (-4° F to 131° F) (must be free from dew condensation)
Finish	Upper cover: Aluminum, White, powder coating Trans case: HIPS, White Screws: Stainless steel Speaker cable: Polyvinyl chloride insulated cabtyre cable (6 mm (0.24") in diameter, 450 mm (17.72") in length), White
Dimensions	ø139 X 149 (D) mm (ø5.47" X 5.87")
Weight	2.7 kg (5.95 lb)

APPEARANCE

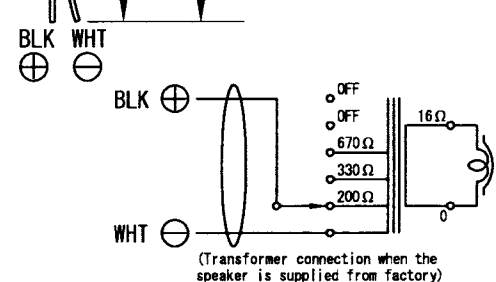
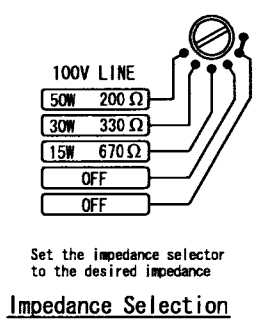
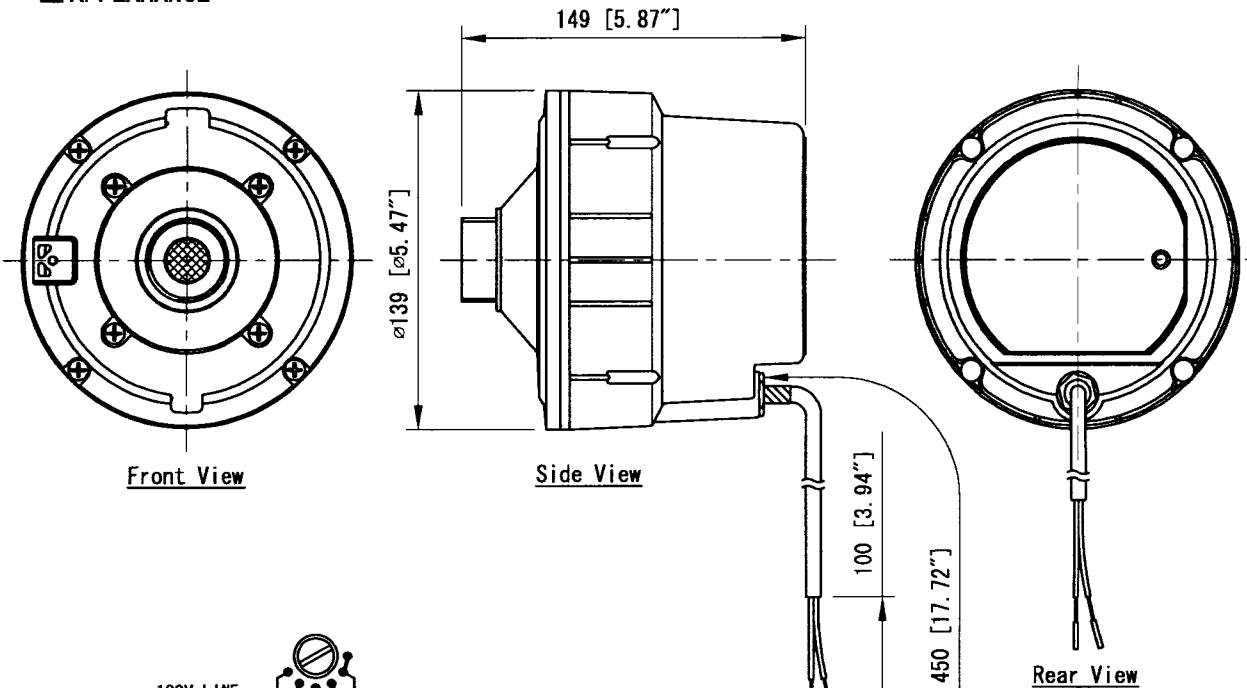

UNIT:mm SCALE:1/3

Date: Jun 17, 2011