



ZS-BS301B

SPEAKER SYSTEM

● DESCRIPTION

The BS-301 series is a high-power speaker with 2-way system that suitable for indoor use only. It consisted of a subwoofer and four pieces satellite speakers. Subwoofer system employing 16 cm speaker units and satellite speaker employing a 8 cm speaker unit. Combined use of the supplied bracket both speakers subwoofer and satellite speakers can be mounted at the wall or ceiling in many different application.

● SPECIFICATIONS

Model	ZS-BS301B
Continuous Program Input	120W per Channel x2
Rated Impedance	6Ω per Channel x2
Sensitivity / SPL	83dB (Pink noise 330 ~ 3,300Hz, 1W, 1M) L or R ch. Subwoofer + 2 satellite
Frequency response	40 ~ 20,000 Hz (L or R ch. Subwoofer + 2 satellite)
Speaker feature	Subwoofer1pc (see on page: 2 / 3 for detail) Satellite speaker4pcs (see on page: 3 / 3 for detail)
Mounting	Floor standing /on-wall /on-ceiling
Satellite system	Self or stack system
Input Connector	Push-in terminals
Total weight	13.9kg (without bracket)

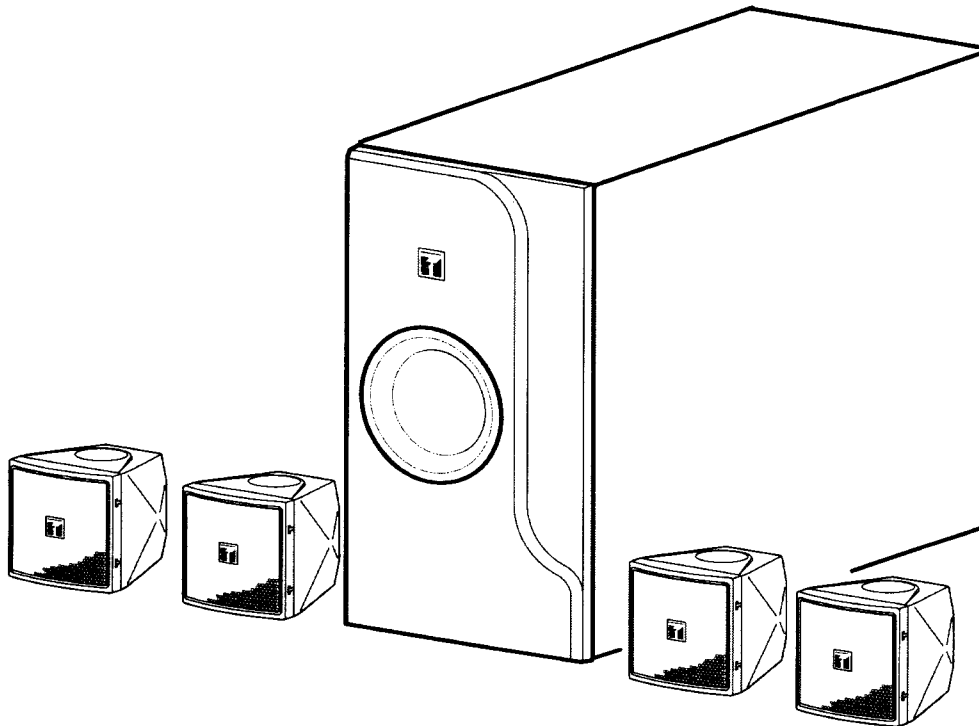

Scale : -

Units : mm



SUBWOOFER

ZS-BS301B

● DESCRIPTION

This speaker is compact subwoofer system that suitable for indoor use which employing 16 cm woofer. It is particularly ideal for reproducing dynamic low frequency for both permanent or temporary installation.

● SPECIFICATIONS

Continuous Program Input	120W per Channel x2
Rated Impedance	6Ω per Channel x2
Sensitivity / SPL	85dB (1W, 1M) (L or R Channel)
Frequency response	40 ~ 190 Hz (-10dB below SPL) (L or R Channel)
Speaker component	Double Subwoofer : 16 cm cone-type
Input / Output Connector	Push-in connector (bridging terminal, 8 pole type)
Front Panel	ABS Resin (Black)
Cabinet	Particle Board with Vinyl Black
Mesh Speaker Grill	MEU R5001 Hard Black
Dimensions	210 (w) x 390 (h) x 563 (d) mm
Weight	11.5 kg (without bracket)
Accessories	Rubber Foot4pcs ; Bracket (Black paint)4pcs Tapping Screw 3x14 4pcs

● APPEARANCE

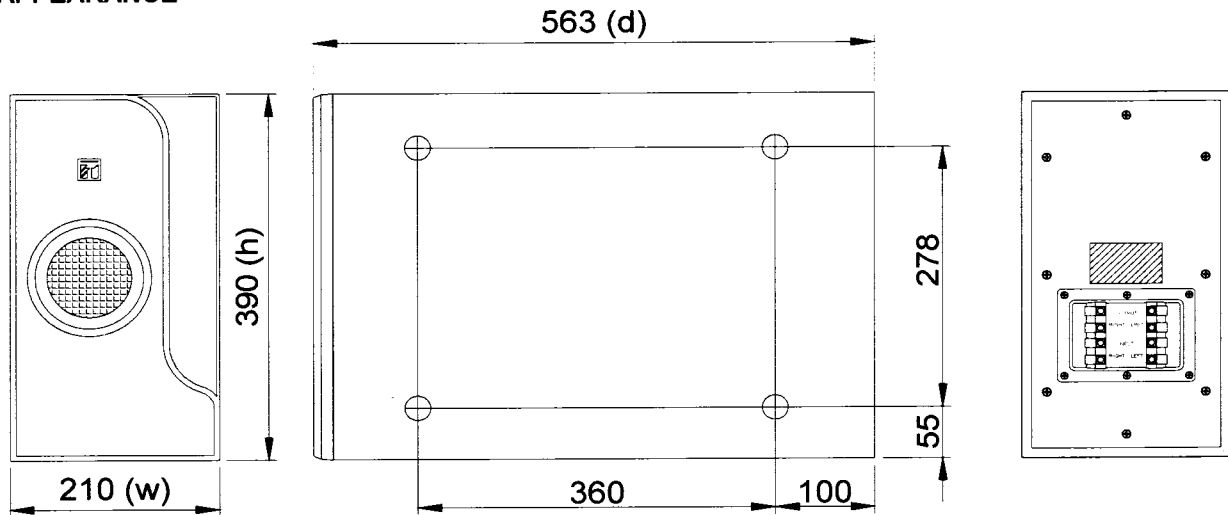

FRONT VIEW

SIDE VIEW

REAR VIEW

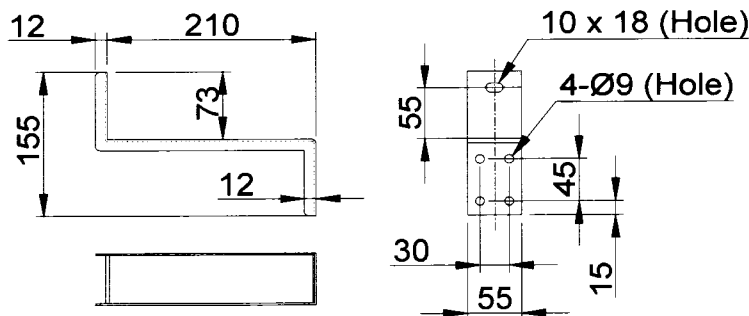

BRACKET

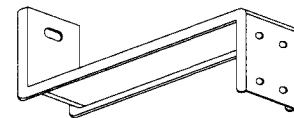

Scale : -

Units : mm



SATELLITE SPEAKER

ZS-BS301B

● **DESCRIPTION**

The speaker is compact speaker system small type designed for high efficiency, wide range especially high frequency result and high power input handling capability.
 Combined used of the supplied bracket the speaker to be mounted in many different application.

● **SPECIFICATIONS**

Continuous Program Input	40W
Impedance	8Ω
Sensitivity / SPL	85dB (Pink noise 330Hz ~ 3,300Hz / 1W, 1M)
Frequency response	150 ~ 20,000 Hz (-20dB below SPL)
Speaker component	8 cm (3") cone-type.
Input Connector	Push-in terminals
Finish	
1 Enclosure	HIPS Resin (Black)
2 Front Cover	
3 Bracket	Steel plate, paint (Black)
Dimensions	92 (w) x 97.5 (h) x 100 (d) mm
Weight	600g (without bracket)
Accessories	Speaker Bracket (Set) 1pc Hexagon bolt M5 x 12 (with washer and spring washer)..... 2pcs

This specifications is one unit satellite.

● **APPEARANCE**

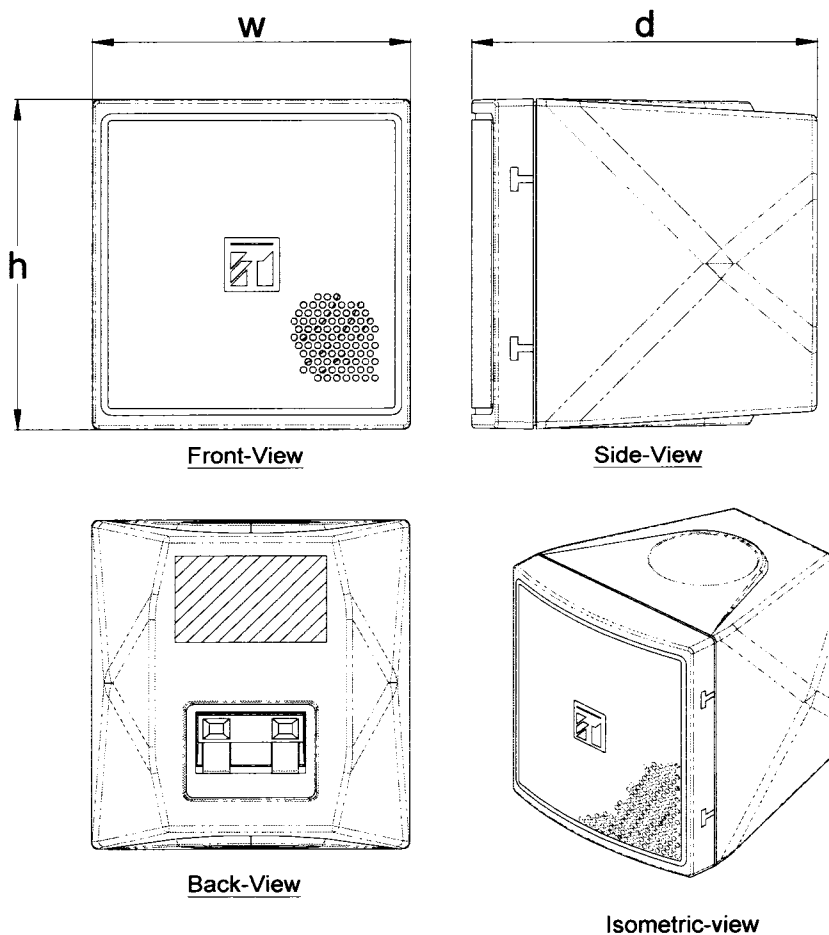

Scale : -

Units : mm

Date : May/12/2010

TOA Corporation

DWG No. 506410011 Rev.02