



Garden Speaker ZGS-301



Made for high performance in tough environments.



ZGS-301

* Photo shows TOA label attached.

The ZGS-301 Garden Speaker satisfies the requirements for a stylish and attractively designed speaker than can be installed in a variety of demanding environments that pose considerable difficulties for conventional speakers. Blending well into the surroundings of various locations, the ZGS-301 offers highly reliable performance that is fully satisfies the IPX4 requirements for environments with exposure to water.

Made for high performance in tough environments.

safe&sound



Easy installation and low maintenance in tough environments.

Description

The ZGS-301 Garden Speaker is a compact speaker that is ideal for applications such as paging and background music broadcasting in various locations such as gardens, theme parks, resort facilities and others. The exterior is formed of corrosion-resistant material that gives it an extended service life in adverse environments (IPX4 category).

The Garden Speakers inconspicuous design enables it to be easily installed in the middle of garden shrubbery and virtually disappear into the surroundings.

Features

- Speaker enclosure composed of FRP resin provides exceptional resistance to corrosion and moisture, making it ideal for installations outdoors.
- Speaker wiring and the base unit may be buried in the ground. The unobtrusive design allows it to easily blend into the surroundings. The speaker can also be positioned in garden shrubbery.
- The ZGS-301 is designed exclusively for high impedance applications and is easily incorporated into a distributed network covering a larger area.

SPECIFICATIONS

ZGS-301	
Enclosure	Sealed type
Rated Input	30W (100V line), 15W (70V line)
Rated Impedance	100V line: 330Ω (30W), 670Ω (15W), 1kΩ (10W), 2kΩ (5W), 3.3kΩ (3W) 70V line: 330Ω (15W), 670Ω (7.5W), 1kΩ (5W), 2kΩ (2.5W), 3.3kΩ (1.5W)
Sensitivity	87dB (1W, 1m)
Frequency Response	100 – 8,000Hz
Speaker Component	12cm splash-proof cone-type
Input Terminal	Push-in terminal
Applicable Cable	Solid copper wire: $\phi 0.8 - \phi 1.6$ mm Stranded copper wire: 0.75 – 1.25mm ²
Water Capability	Meets IPX4 requirements
Finish	Top cover and base: FRP resin, dark gray, semi-gloss, paint Speaker panel: ABS resin, dark gray, semi-gloss, paint Legs: Aluminum, dark gray, semi-gloss, paint
Dimensions	$\phi 270 \times 335$ (H)mm
Weight	2.4kg
Accessory	TOA label $\times 2$

APPEARANCE AND DIMENSIONAL DIAGRAM

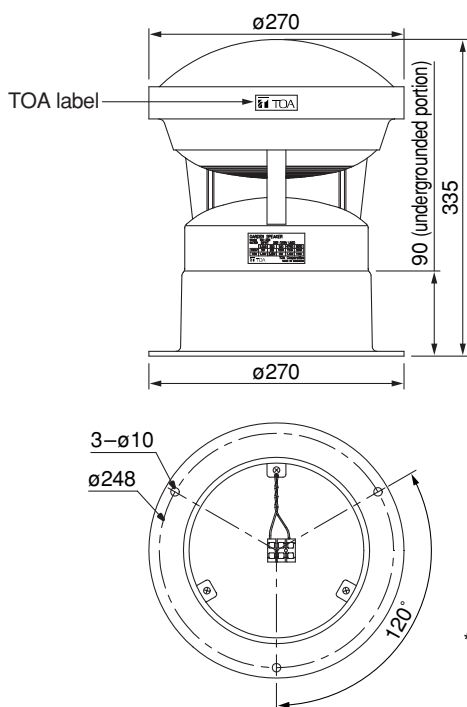

WIRING DIAGRAM

