

DESCRIPTION

The ZH-615R is a compact, highly intelligible speaker suited to public address announcement applications.

SPECIFICATIONS

Rated Input	15 W
Rated Impedance	8 Ω
Sound Pressure Level	110 dB (1 W, 1 m at 500 Hz to 2.5 kHz peak level)
Frequency Response	280 Hz - 12.5 kHz
Polarity	Hot: Black , Com: White
Operating Temperature	-20 °C to +55 °C (must be free from dew condensation)
Finish	Horn flare: Aluminum, off-white Reflector horn and rear cover: ABS resin, off-white Bracket, screws and bolts: Steel Speaker cable: Polyvinyl chloride insulated cabtyre cable (6 mm in diameter, 400 mm in length)
Dimensions	∅ 196 (W) x 240 (D) mm
Weight	1.1 kg

Note: Avoid installing the speaker in locations which vibrate considerably, or under environments easy to be oil-contaminated.

APPEARANCE

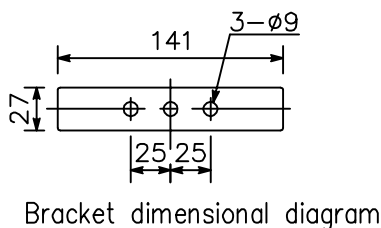
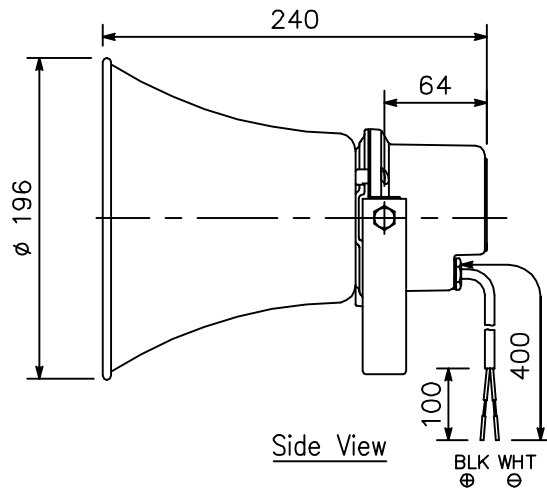
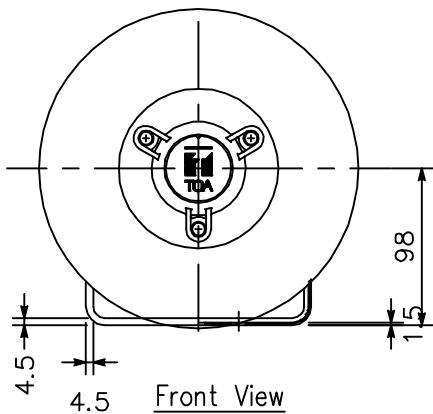
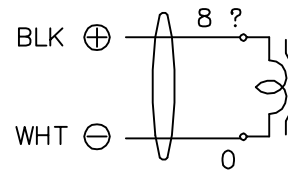
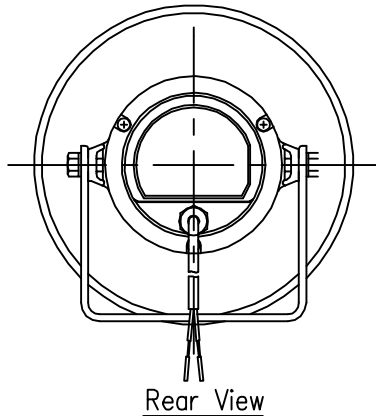

UNIT: mm SCALE: 1/5