

DESCRIPTION

The DM-1200 microphone is designed for speech applications and features high intelligibility.

SPECIFICATIONS

Type	Moving coil microphone
Directivity	Unidirectional
Rated Impedance	600 Ω, balanced
Rated Sensitivity	-52 dB (1 kHz 0 dB=1 V/Pa)
Frequency Response	50 Hz - 12 kHz
Connection Cable	Single-core shielded cable, unbalanced
Cable Length	10 m
Terminal of Cable	Phone plug
Talk Switch	Short-off, slide switch
Finish	Body: Die-cast zinc, metallic gray Head: Die-cast aluminum/zinc-plated steel wire, metallic gray
Dimensions	∅39.5 X 163 mm (microphone body)
Weight	265 g (without connection cable)
Accessory	Microphone holder (U5/16, NS5/8, W3/8)---1

APPEARANCE

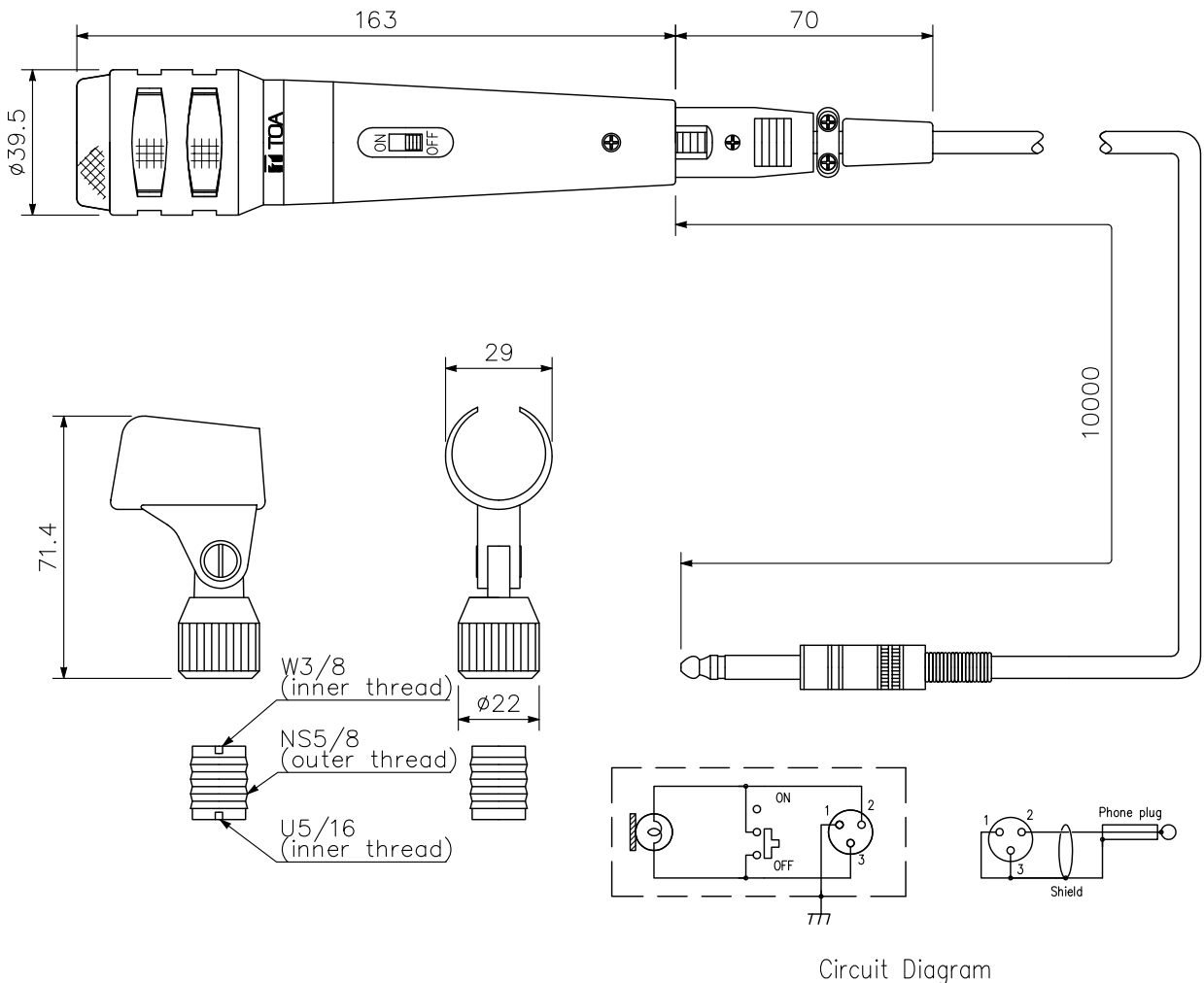

UNIT:mm SCALE:1/2

Circuit Diagram